

Geda Materials Hoist Operating Instructions

Novocastrian Rentals P/L ABN 27 110 725 623

1 Purpose of Equipment

Geda Rack & Pinion Hoists are temporarily erected hoist systems that are intended exclusively for transporting goods. Materials Hoists are **NOT** intended for the carriage of humans or animals.

2 Safety

2.1 Warnings

The Hoist is constructed using state-of-the-art technology and is safe to operate. However, the nature of the operating procedures is such that the Hoist has areas and parts that cannot be protected without impairing the function and operating capability. Therefore good personal safety practice is essential to protect personnel and the Hoist.

- The Hoist can present dangers if it is used incorrectly by untrained personnel or if it is not used in accordance with regulations.
- Read and understand these instructions first before setting up or operating this equipment
- Keep these instructions accessible near the Hoist.
- Before beginning work, one should become familiar with the working environment.
- No changes, additions or modifications may be made to the Hoist or associated equipment.
- Do not modify, remove, bypass or override the safety devices.
- Have the area around the Hoist barricaded off and post warning notices.
- Observe National Plant Regulations and Occupational Health and Safety Regulations.
- In situations that are dangerous or potentially dangerous to the operating personnel or to the hoist, pressing the **EMERGENCY-STOP** button can stop the Hoist.

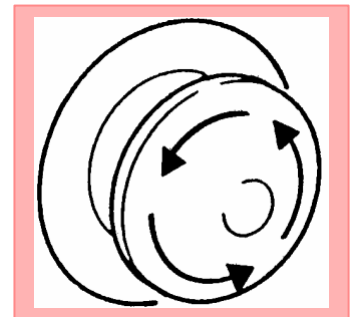

Fig. 1 EMERGENCY-STOP button

2.2 Certification

A Certificate of Competency is required to operate this Hoist. The Operator must be familiar with the Operating Instructions, possess adequate experience and be aware of the dangers involved with the Hoist.

2.3 Log Book

A continuous working record (i.e. logbook) of the significant events concerning the safety and operation of the Hoist shall be kept and retained on the Hoist. Refer to AS 2550.7 Section 9.6 for details.

2.4 Incident Notification

The employer, as defined by the Regulations referred to below, who has management or control of the workplace must be aware that they may have an obligation to notify WorkCover of any incidents involving this equipment. Refer to the Occupational Health and Safety Act and the Occupational Health & Safety (Incident Notification) Regulation(s) applicable to your State

2.5 Inspections

Inspections as detailed in Chapter 6: Maintenance should be performed before Installation or Use of this equipment.

2.6 Hazard Assessment

Please note that this checklist is indicative only. Users must perform their own Risk Assessment subject to the intended siting and use of the equipment.

Hazard	Risk	Control
Crushing by the Hoist collapsing, tipping or rolling	Moderate	<ul style="list-style-type: none"> Ensure that the load does not protrude from the platform and the Hoist is always observed during operation, or the load may catch leading to the Hoist toppling. Ensure that the Hoist has been assembled on firm level ground only. Check the area under the Hoist has not been cut, bored, eroded or otherwise become unstable. Ensure the securing structure is of adequate strength. Ensure that the Hoist is correctly attached with adequate bracing and fixtures. Regularly check mast bolts, bracing and fixings for soundness. Do not remove bracings or fixings Check the Hoist mast is vertical in both elevations. Do not overload the Hoist, or allow loads to protrude. Do not operate in extreme weather conditions.
Crushing or shearing by trapping between the Hoist and fixed structures, or Hoist parts.	Moderate	<ul style="list-style-type: none"> Barricade a work-space around the base of the Hoist to prevent personnel standing underneath the Hoist Ensure the base area is unobstructed before lowering the Hoist in the final 2m zone. Keep body parts clear of the Hoist and it's components while in motion. Keep fingers and toes clear of the Loading Ramps.
Falling when unloading a raised platform	Moderate	<ul style="list-style-type: none"> Barricade area at height to prevent falls. Ensure Landing gates or barriers remain closed except during loading/unloading. Do not step onto a raised platform.
Striking or crushing by materials falling from the equipment	Low	<ul style="list-style-type: none"> Barricade a work-space around the base of the Hoist to prevent personnel standing underneath the Hoist Do not overload the Hoist. Loose or suspect materials should be adequately secured before hoisting. Do not carry protruding loads.
Electrocution	Low	<ul style="list-style-type: none"> Operate from a protected supply only. Do not operate in a liquid environment.
Explosion	Low	<ul style="list-style-type: none"> Do not operate near naked flames. Do not operate in an explosive environment.
Cutting, stabbing or puncturing	Low	<ul style="list-style-type: none"> Ensure mesh on platform and Landing Gates is in good condition. Do not carry protruding loads.
Crushing or entanglement when inspecting or maintaining the Hoist	Low	<ul style="list-style-type: none"> Do not place body parts against the Hoist when in operation. Wear close fitting clothing Do not wear jewellery such as chains or rings.

3 Specifications

Model	500/300Z	500/300L	500Z/500
Maximum Load Capacity (evenly distributed)	300kg	500kg	500kg
Supply Voltage	240v 9.5A	240v 10.5A	415v 11.4A
Lifting Speed	13m/min	9m/min	25m/min
Maximum Lifting Height	50m	50m	100m
Platform size	900mm x 1750mm	1600mm x 1750mm	1600mm x 1750mm
Platform Loading Ramp size	600mm x 920mm	600mm x 1770mm	600mm x 1770mm
Height to platform when completely lowered	300mm	300mm	300mm
Ground Bearing Area	0.25m ²	0.4m ²	0.4m ²
Base Mass	490kg	550kg	520kg
Mast Mass	48kg	48kg	48kg

4 Description

4.1 Outline

- During operation the Hoist is controlled by means of the mobile Hand Control at the Switchbox on the cable bin.
- An Overspeed Governor prevents a free-fall from a drive or brake failure.
- Floor Stops may be fitted to the Hoist to allow stops at a pre-determined point. Pressing the UP button slightly will cause the Hoist to stop automatically at the next Floor Stop fitted. Pressing the UP button completely will cause the Hoist to rise continuously until the button is released or the Working Limit is reached.
- Landing Gates interlocks and signalling system connected to the Hoist operate on 48vAC and do not require additional insulation (see AS 3000 Wiring Rules)

4.2 General Arrangement

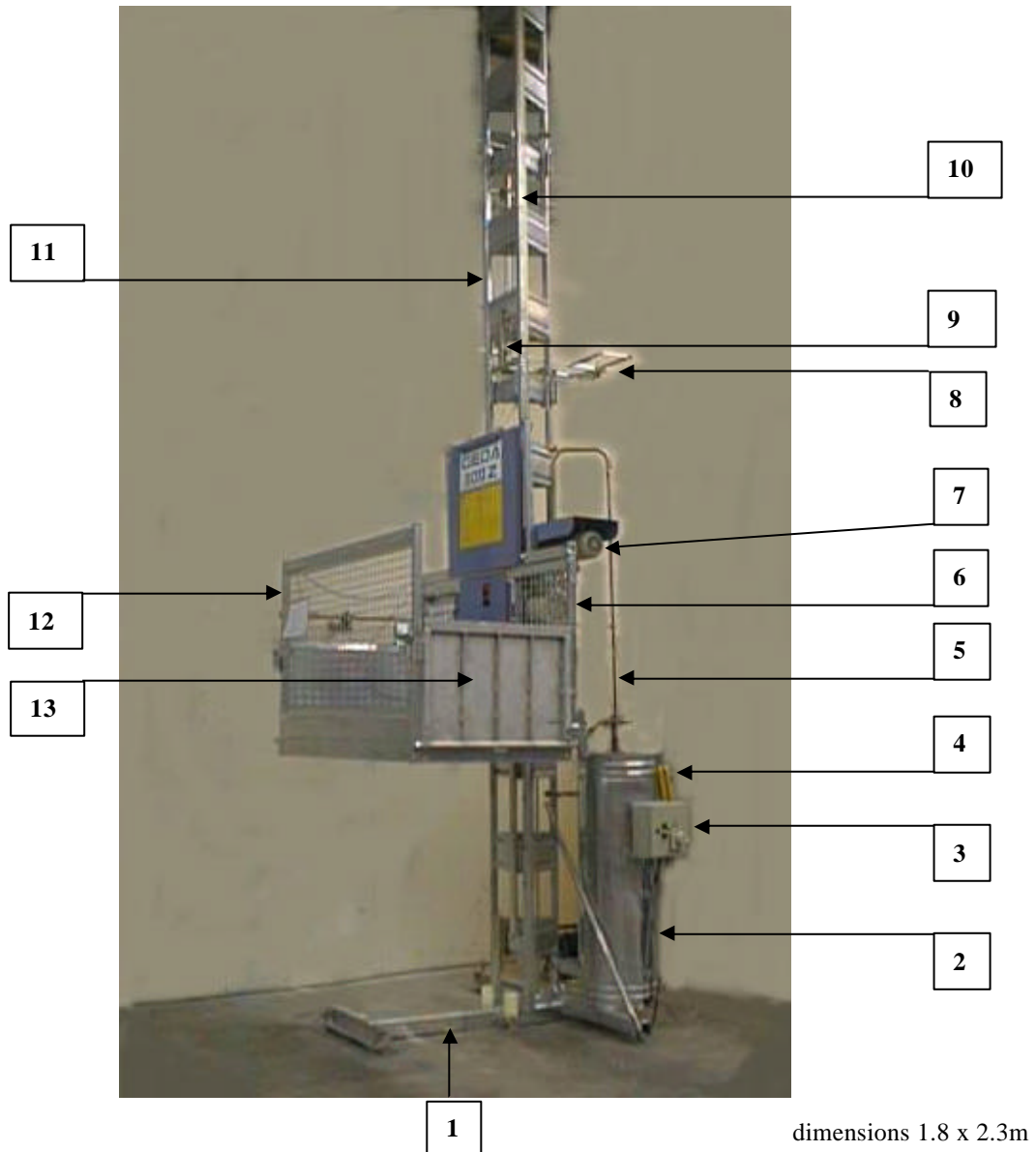
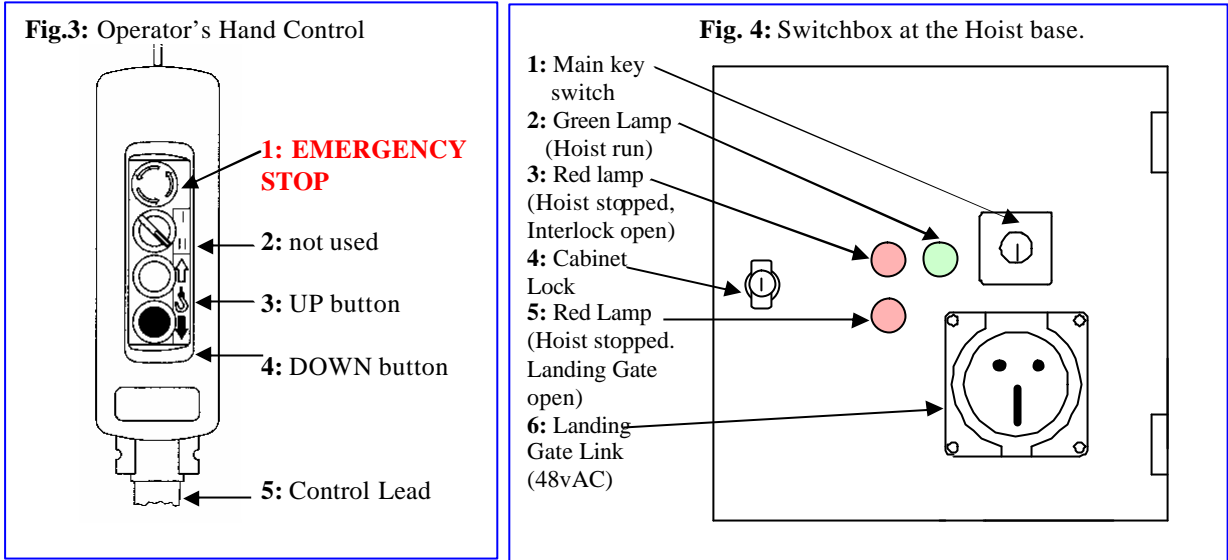

Fig. 2: Hoist Components

1	Hoist Base	6	Overspeed Governor	11	Mast Section
2	Cable Drum	7	Motor/Brake	12	Platform
3	Switchbox	8	Cable Guide	13	Loading Ramp
4	Hand Control	9	Landing Stop		
5	Trailing Cable	10	Working / Final Limit		

4.3 Controls



4.3 Travel Limit Switches

- Normal operational up travel is limited by a Working-Limit switch activated by a red plate fitted to the mast above the topmost landing point [Fig. 6]. This limit switch will be reached if the UP button is completely pressed, or the UP button is pressed in AUTOMATIC mode while the platform is at the uppermost landing. Pressing the DOWN button in either mode will allow the platform to descend off this limit switch.
- Down travel is limited by a Working-Limit switch activated by a plate fitted to the mast so the platform stops at ground level. Pressing the UP button in either mode will allow the platform to move off this limit switch.
- An upper Final-Limit switch is tripped by the red activating plate [Fig. 6] fitted to the mast above the topmost landing point. The Final-Limit switch will only be tripped by failure of the Working-Limit switch. It is not possible for the Operator to move the platform off this limit switch and Conveyor & Hoist Rentals P/L must be contacted for corrective action.
- A Proximity switch is also fitted to limit upper travel if the red Limit switch activating plate is removed or tampered with.
- If the red Limit switch activating plate and Proximity switch are tampered with or removed, the hoist design will ensure the drive sprocket will over-run the mast but the platform will be retained on the mast by all keepers and guides.
- A lower Final-Limit switch is tripped if the hoist over-runs the lower Working-Limit switch. The Operator cannot move the hoist platform if this switch has been activated and Conveyor & Hoist Rentals P/L must be contacted for corrective action.
- Failure, removal or tampering with the Working-Limit and Final-Limit switches in the down direction will result in the drive pinion causing a special section of rack to be torn off, preventing any hoist operation until the Supplier has been contacted for corrective action.
- Automatic Landing stop may be set by fixing a Landing Stop plate on the mast as shown in Fig. 5

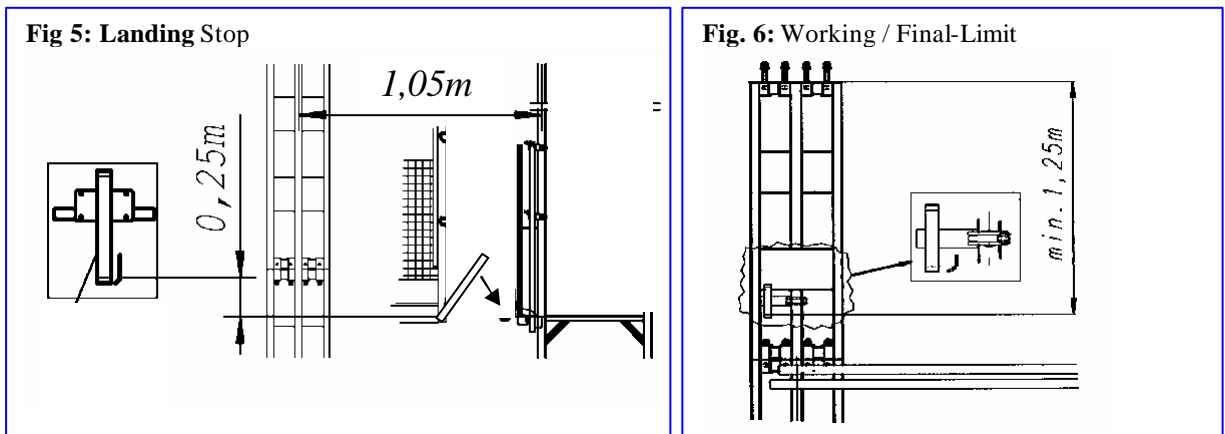

5 Operation

5.1 Pre-Operation

- Read the Warning notices in Chapter 2 and implement a Risk Assessment before starting work
- Perform maintenance as described in Chapter 6
- Do not work beneath; step over or into the Hoist.
- Always wear personal protective equipment.

5.2 Prohibitions

- Do not hoist people or animals.
- Do not exceed the loading specifications stated in Chapter 3
- Do not operate with the load on one side of the platform only or a load protruding over platform edges.
- Do not operate in wind speeds of more than 70km/hr
- Do not operate if the Hoist or any of its components are damaged
- Do not operate if required Maintenance has not been performed.
- Do not use this Hoist if there is any damage or unusual performance. Isolate the Hoist as described in Chapter 7.1 Emergency Shutdown.
- Do not operate the Hoist if there is a risk of people being endangered by the load or platform.
- Do not operate in poor conditions (below -15°C or above 45°C, fog, ice, naked flames etc)
- Do not operate if upper and/or lower Travel Limit switches have not been set.
- Do not operate if any bracing or fixings have been loosened or removed.

5.3 Beginning of Work Period Start-up

- Turn the Keyed Isolator Switch [#1 in Fig.4] on the Switchbox to “ON”
- Check that the platform is unloaded.
- Check that personnel and/or animals are not near or on the platform.
- Check all ramps and covers are closed firmly.
- Turn the **EMERGENCY STOP** [#1 in Fig. 3] button clockwise to release.
- Verify that the green lamp [#2 in Fig. 4] is lit. See Chapter 5.5 if not lit.
- Press and hold the black UP button [#3 in Fig. 3] to raise the platform 2 metres.
- Release the button and check the Hoist stops instantly and the platform does not descend under its own weight.
- Press and hold the black DOWN button [#4 in Fig. 3] and lower the platform 1 metre.
- Release the button and check the Hoist stops instantly and the platform does not descend under its own weight.
- Lower the platform to the ground and place a suitable load on the platform.
- Repeat the above lift test
- Check that the Trailing Cable [#6 in Fig.1] winds and unwinds regularly from its container.

5.4 Loading or Unloading the Platform

- Refer to Fig. 7
- The load platform must always be loaded in such a way that there is free access for loading and unloading.
- The load must be evenly distributed on the platform.
- Bulky goods must not protrude laterally over the platform.
- The load must be positioned securely. Materials that tend to slip, or is higher than the platform or could fall over, must be adequately secured.
- Consideration should be given to the effects of sudden wind gusts on the security of the load.

Fig. 7: Prohibited loading

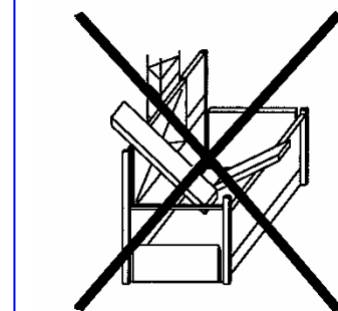

5.5 Indicator Lamps

- The green lamp [#2 in Fig. 4] is lit when all Hoist & Landing Gate Interlocks are closed and all Emergency Stop switches have been released.
- The top red lamp [#3 in Fig. 4] is lit when a Hoist Interlock is open such as a Loading Ramp. The Hoist will not run.
- Both red lamps [#3 and #5 in Fig. 4] are lit when a Landing Gate is open, the Landing Gate connection to the Hoist is loose, unplugging or removing the Landing Gate link or the Emergency Stop Button [#1 in Fig. 3] has been pressed on the Hand Control. The Hoist will not run.

5.6 Regular Operation

Refer to Fig. 3 and Fig 4 in Chapter 4

1. Turn on the Main Key Switch [#1 in Fig. 4]
2. Turn the **EMERGENCY STOP** Button [#1 in Fig. 3] clockwise to release.
3. Check the green lamp is lit [#2 in Fig. 4]. Refer to Chapter 5.5 if not lit.
4. Firmly press and hold the UP [#3 in Fig. 3] button to cause the platform to rise.
5. Release the button to stop.
6. Firmly press and hold the DOWN [#4 in Fig. 3] button to cause the platform to lower.
7. Release the button to stop.
8. Up and down motions may be ceased at any time by releasing the motion button or by pressing the **EMERGENCY STOP** [#1 in Fig. 3] button.
9. Up and down motions will be limited by a Limit Switch – see Chapter 4.4

5.7 Floor Stop Operation

Refer to Fig. 2, Fig. 3 and Fig. 5

- Automatic stop at the next landing is available in the UP mode only. Operation in the DOWN mode will cause the platform to descend from a point to the ground.
- Automatic stop at the next landing will occur if:
 - A Landing Stop has been fitted to the mast [#10 in Fig.2, Fig. 5]
 - The UP button is pressed slightly
- Release the button to stop.

6 Operator Maintenance

6.1 Daily

- Perform an empty test run and check that:
- Working-Limit switches top and bottom are functioning
- Loading ramps lock correctly and the Hoist does not function if opened
- **EMERGENCY OFF** button is functioning and the Hoist does not move
- When electrically connected to the Hoist, an open Landing Gate will not allow Hoist operation

6.2 Fortnightly or after Adverse Weather Conditions

- Brake test. Load the platform with a load equal to the rated capacity and check that the platform does not move downward when the Hoist is not operated.
- Lubricate the toothed rack and driving pinions with general grease.
- Check the trailing cable, mains supply and control leads for damage.

7 Shutdown

7.1 Emergency Shutdown

- Stop operation of the Hoist by either:
 1. Releasing the UP or DOWN buttons [see Fig. 3].
 2. Pressing the **EMERGENCY-OFF** button [#1 in Fig. 3].
 3. Turning off the power supply [#1 in Fig. 4].
- Remove the power supply from the Hoist.
- Erect a sign stating “DO NOT USE – HOIST UNDER REPAIR” and fix to the Hoist.
- Inform management or management’s agent of the situation.

7.2 End of Work Period / End of Hire Shutdown

- Unload the Hoist and lower the platform to the ground.
- Turn the keyed Main Isolator to “OFF” and withdraw the key [#1 in Fig. 4].
- Remove the power supply and secure the key in a safe place.
- Clean any dirt or grease from the Hoist.

8 Installation and Removal

Refer to Form 0504 for Installation and Removal Instructions